

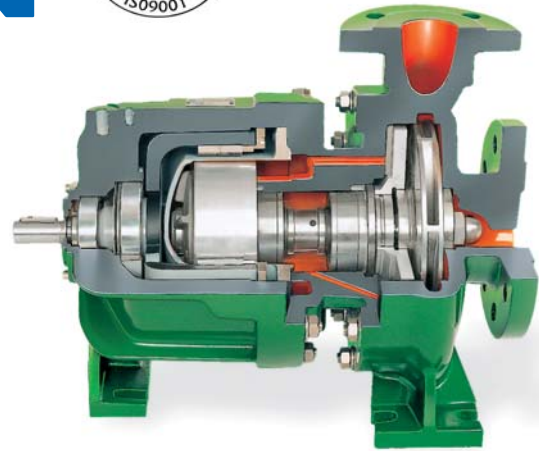

**DICKOW  
PUMPEN**



**Sealless Magnetic Coupled  
Centrifugal Pumps  
acc. to EN 22858 / ISO 2858**

**Type NML / NMB**

*our  
contribution  
for  
environmental  
protection*

## General

Magnetic coupled DICKOW-pumps of the series NM are sealless pumps. The static containment shell forms a closed system with hermetically sealed liquid end.

## Applications

Magnetic coupled NM-pumps are designed to improve plant and personnel safety, especially when handling toxic, explosive or other dangerous liquids which react on contact with the atmosphere. For all these services the containment shell replaces the double acting mechanical seal with external fluid reservoirs and the necessary control equipment. NM-pumps therefore offer exceptional benefits to the chemical, petrochemical and allied industries, and protect the environment.

Max. capacity and differential head:  
50 Hz – appr. 400 m<sup>3</sup>/h and appr. 150 m  
60 Hz – appr. 480 m<sup>3</sup>/h and appr. 220 m  
(appr. 2100 gpm and 720 ft)

The maximum operating temperature is 200°C (390°F) for NML-series and 240°C (464°F) for NMB-series. Higher temperatures are possible with the pump types NMR / NMWR.

## Hazardous area

Together with suitable Ex-drive motors, the NML/NMB-pumps can be applied in hazardous area Group II, Category 2. The pumps meet the basic safety and health requirements of Explosion-proof Directive 94/9 EC and are suitable for plants with increased safety requirement.

For close coupled pumps (NMB) the containment shell temperature is limited when using ex-motors. The values are available on request.

## Design / Pump casing

NML-pumps are single stage volute casing pumps with closed impellers, back-pull-out design, with end suction and top discharge flange. Sturdy feet are provided as standard for mounting on the base plate.

Capacity and outer dimensions comply with DIN EN 22858 resp. ISO 2858.

## Containment shell

The containment shell is a pressure vessel to separate the pumped liquid from the atmosphere

only. The shell is not used as an additional bearing holder. Therefore, no dynamic stress occurs.

The standard containment shell is a one piece deep-draw design without additional welds made of 2.4610 (Hastelloy C).



Other available material options are:

- Zirconium oxide (industrial ceramic) without eddy current losses.
- PEEK composite (carbon fibre reinforced Polyetheretherketon) without eddy current losses.
- Titanium for high pressure applications.

The containment shell is bolted to the bearing housing in a manner that allows removal of the bearing bracket (NML-pumps) respectively of the drive motor (NMB-pumps) together with the drive rotor without draining the pump.

## Magnet coupling

The single elements of the multipolar magnet coupling are manufactured of permanent magnet material "Cobalt Samarium" with unlimited life-time. The magnets in the driven rotor are completely encapsulated, not in contact with liquid. Power is transmitted to the hermetically sealed liquid end by a bank of external magnets. Inner and outer magnet rings are locked together by magnet forces and work as a synchronous coupling. The inner magnet ring transmits the required torque direct to the impeller. Overload of the magnet coupling and slipping will not cause demagnetization if temperature monitoring is available. The magnet couplings are designed for electric motors, direct on line starting. Should a increase of motor power be required, i.e. when

installing a larger impeller, the nominal power of coupling can be increased with additional magnets.

The maximum drive power of NML/NMB-pumps is approx. 111 kW at 50 Hz (135 kW resp. 179 hp at 60 Hz).

### Internal clearances

The internal clearance between rotor and containment shell is appr. 1,0 mm for standard containment shells. This allows – together with the wear resistant SiC sleeve bearings – handling of solid containing fluids.

### Containment shell protection

The clearances between drive rotor and bearing bracket respectively between bearing bracket and containment shell are arranged such that rubbing of the magnets on the containment shell will be avoided, even in the case of worn out ball bearings.

### Casing drain

Complete drainage of casing and magnet end is possible through casing drain. No additional drain is required.

### Outer ball bearings

The drive shaft of the NML-pumps is carried by generously dimensioned antifriction bearings, grease filled for lifetime and protected against the atmosphere by a lip seal.

The drive rotor of NMB-pumps is mounted on the motor shaft. That means, additional bearings, elastic coupling and coupling alignment are not required.

### Double sleeve bearings

The pump shaft is carried by wetted sleeve bearings. Standard material is pure Silicon Carbide with diamond layer, providing limited dry-run capability. SiC is highly resistant to corrosion and wear and can be used for all kind of liquids, also for solid containing products. The SiC-components are shrinkfitted or elastically beared by tolerance rings and therefore protected against shock and thermal stress. Both sleeve bearings are bolted in one common bearing housing to grant correct alignment.

### NPSH-conditions / Inducer

Due to the internal circulation from discharge to discharge, there is no temperature elevation in the impeller eye. Handling of boiling liquids is therefore possible and there is no increase of NPSH-required.

Inducers to improve NPSHR are available on request.

### Balanced thrust loads

The thrust loads of the closed impellers are hydraulically balanced by wear rings, balance holes, back vanes and / or auxiliary impeller. The pump shaft connected to the impeller is floating.

### Monitoring

Connection for temperature sensor for containment shell surface is available as standard. Dry running protection, monitoring of ball bearings and pump protection with the patented “mag-safe“ system is highly recommended.

### Internal circulation, pressurized magnet end

When pump is in operation it generates eddy currents which heat up the containment shell and the liquid in the magnet area. This heat is dissipated by internal circulation with auxiliary impeller:

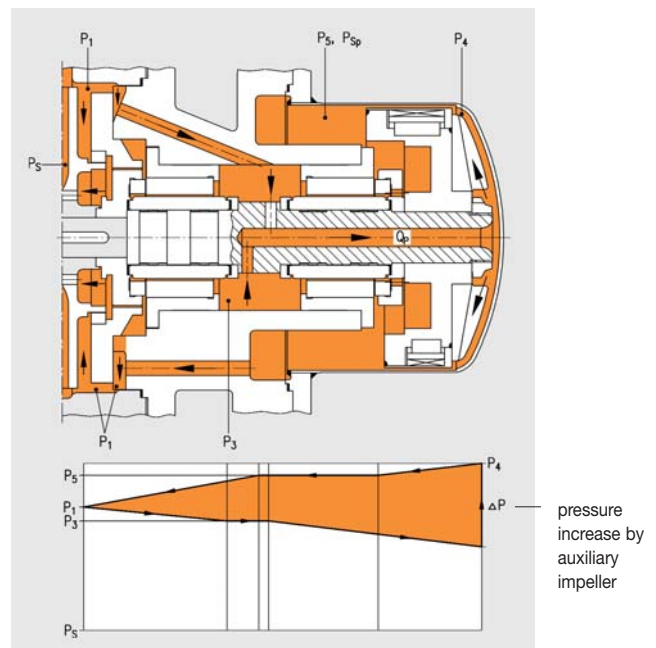

**NML-Design**

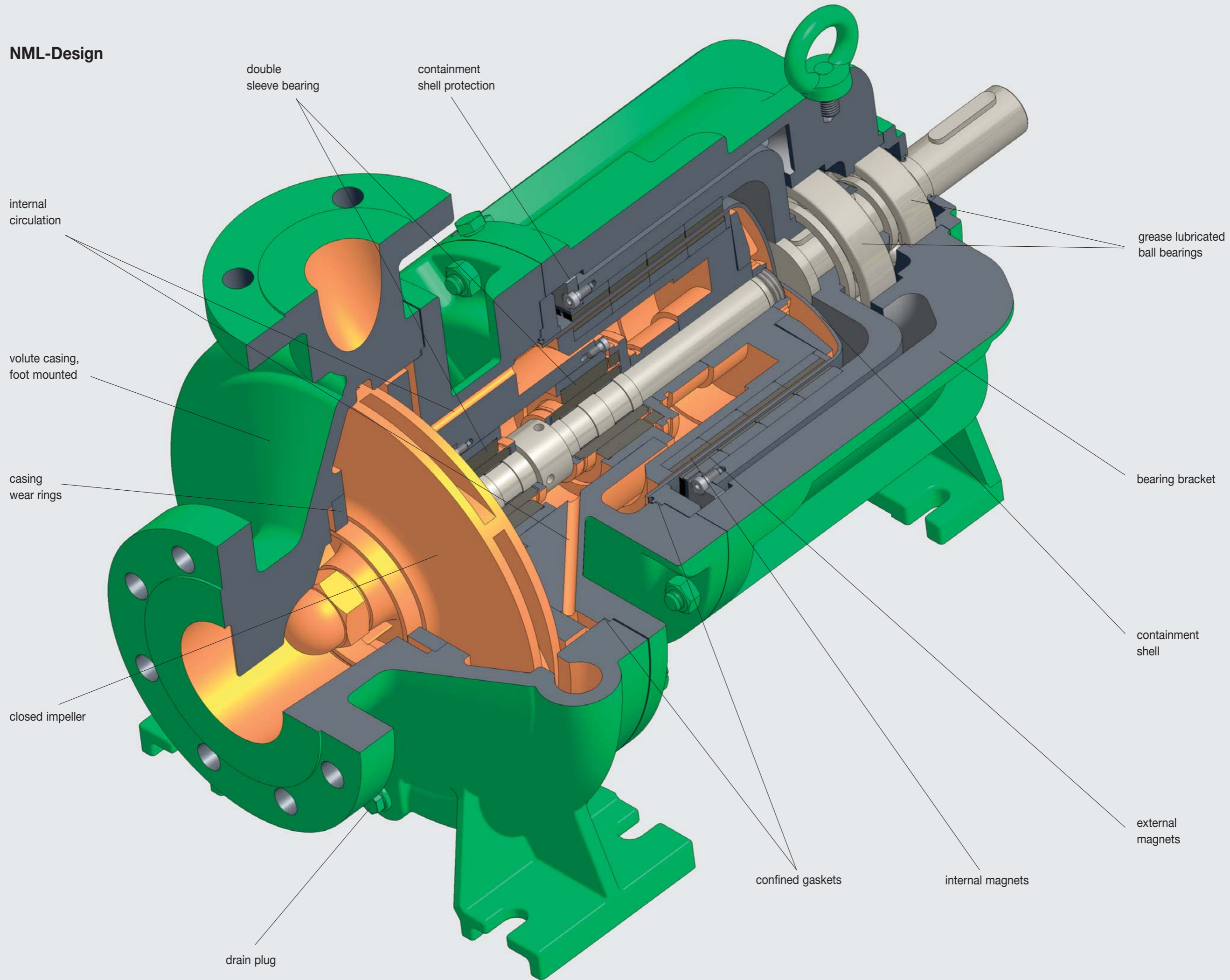

## Optional designs

### Type NMB – close coupled design

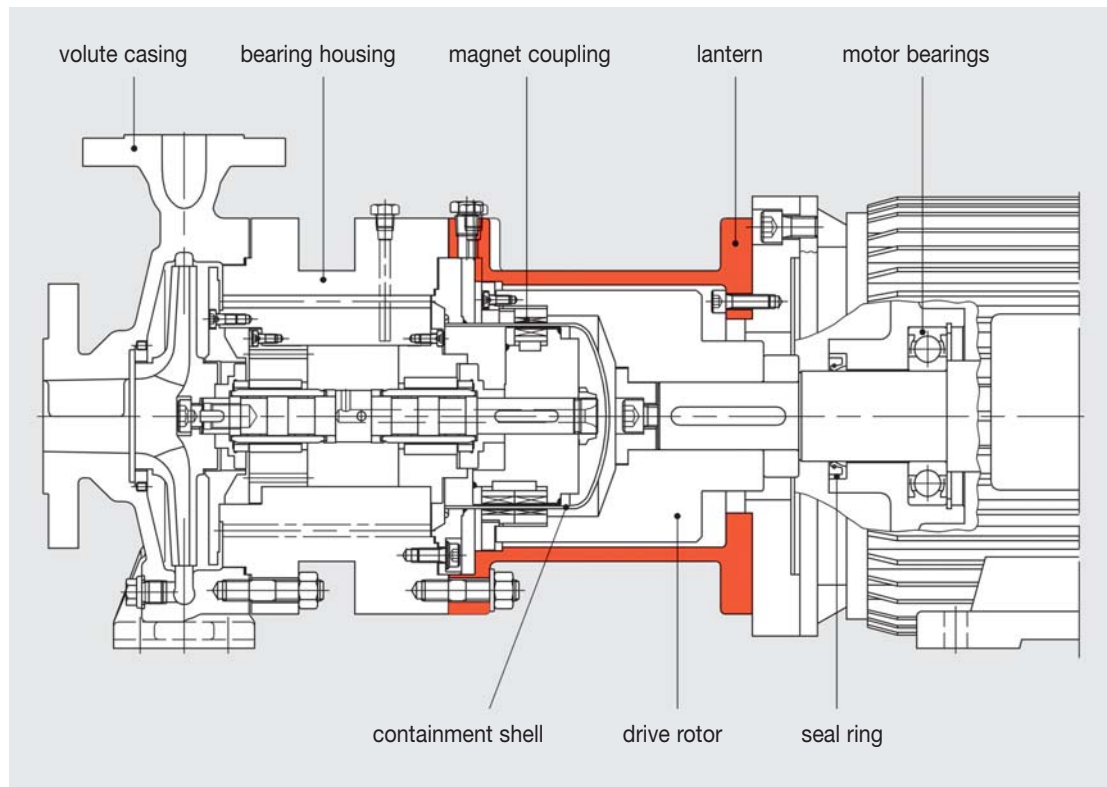

### Type NML b – with heating jacket

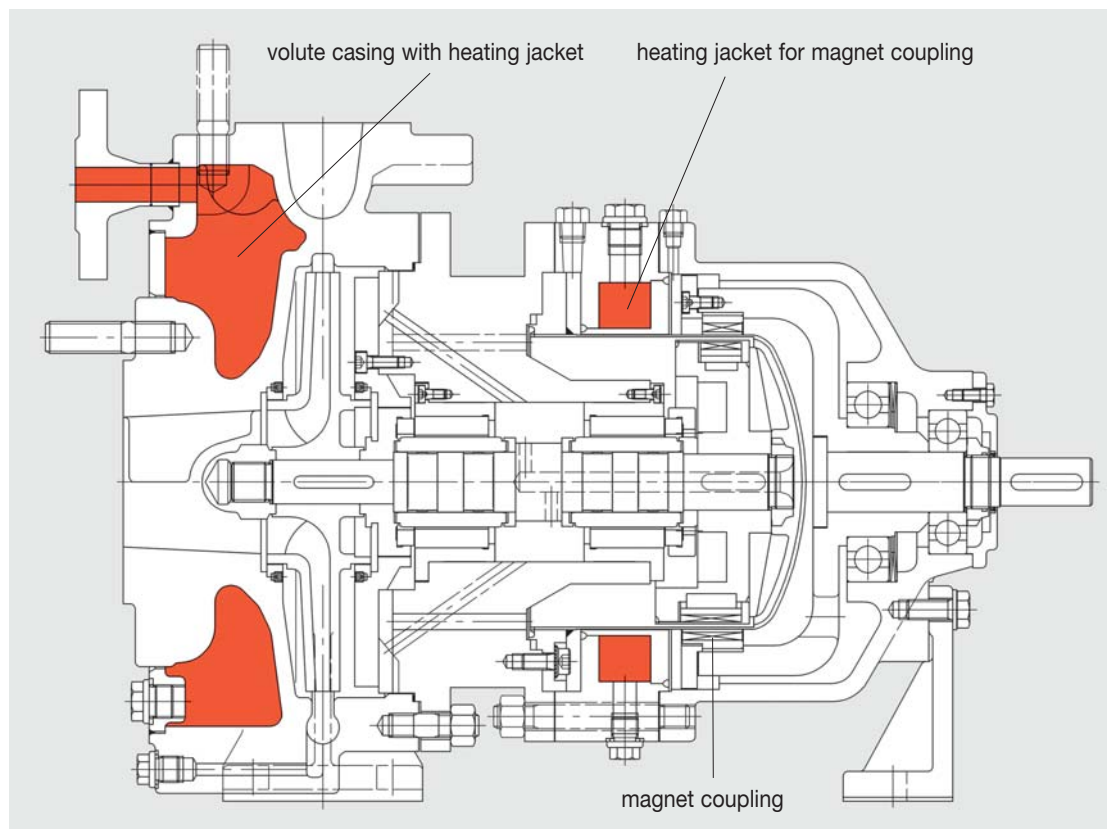

**Type NML o - with open impeller**

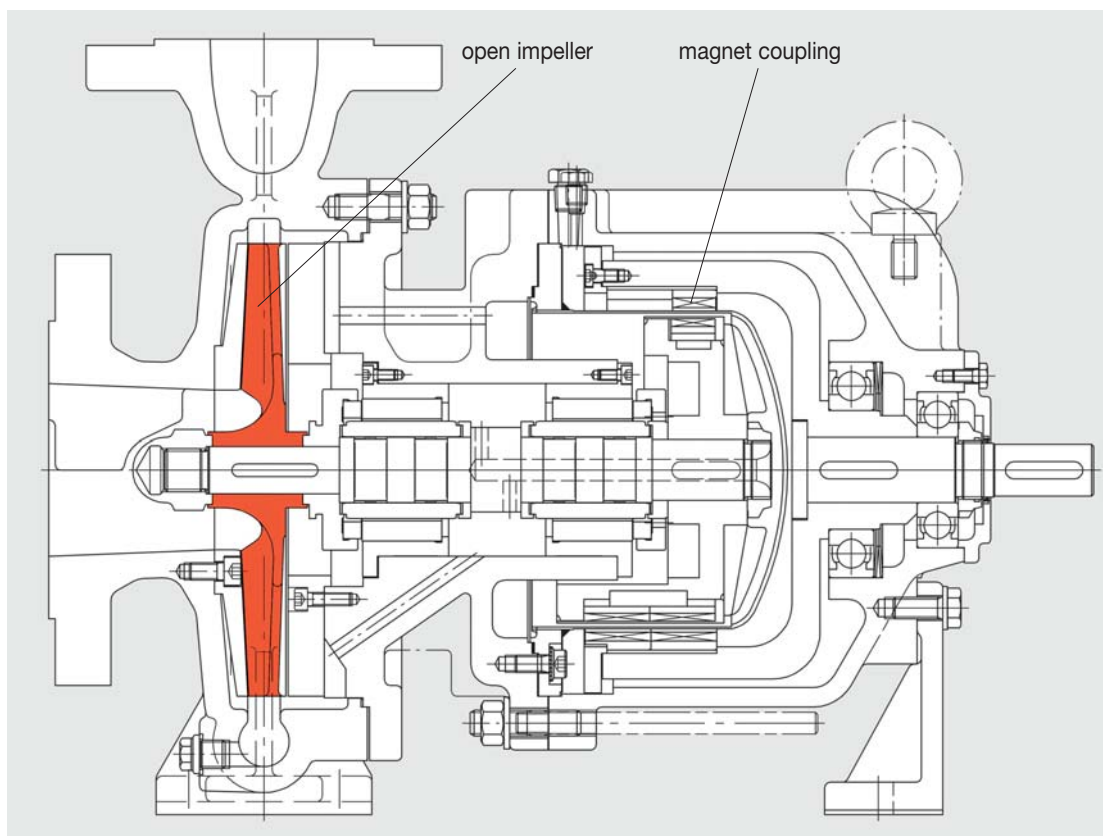

**Type NHM - hot water design**

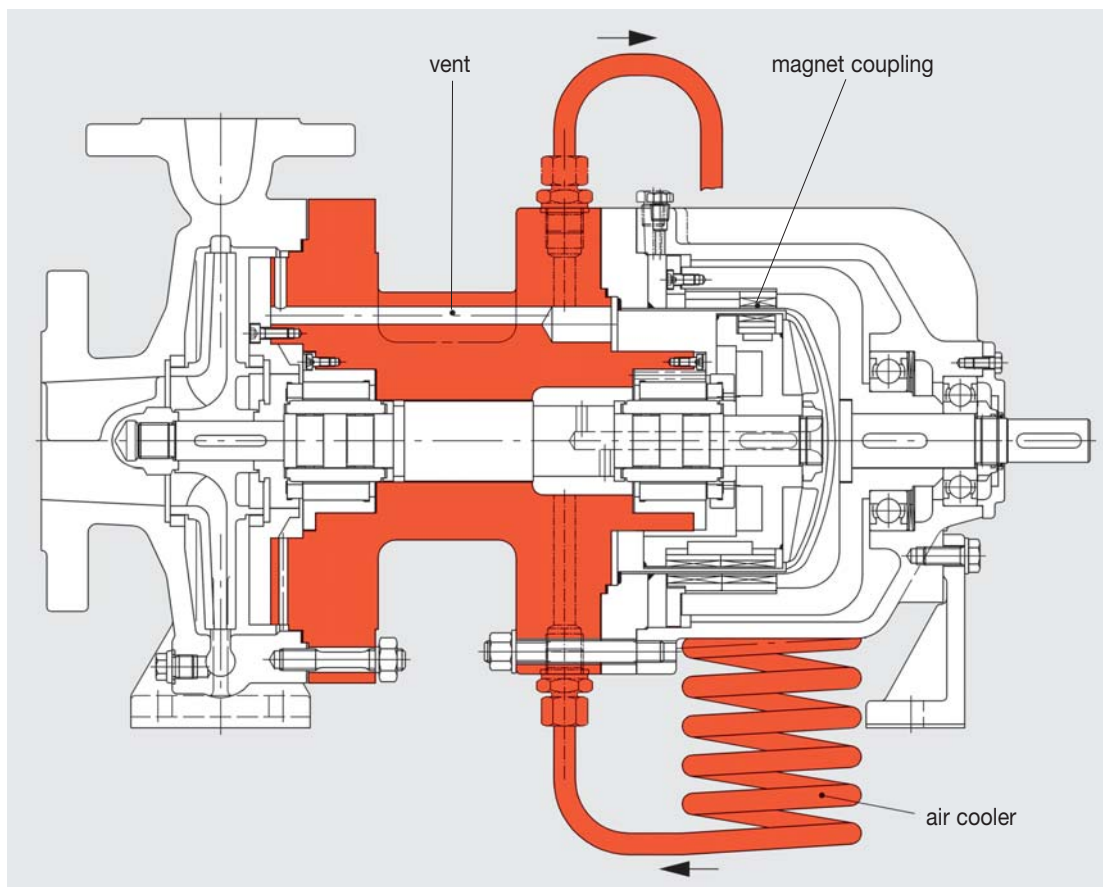

## Performance range

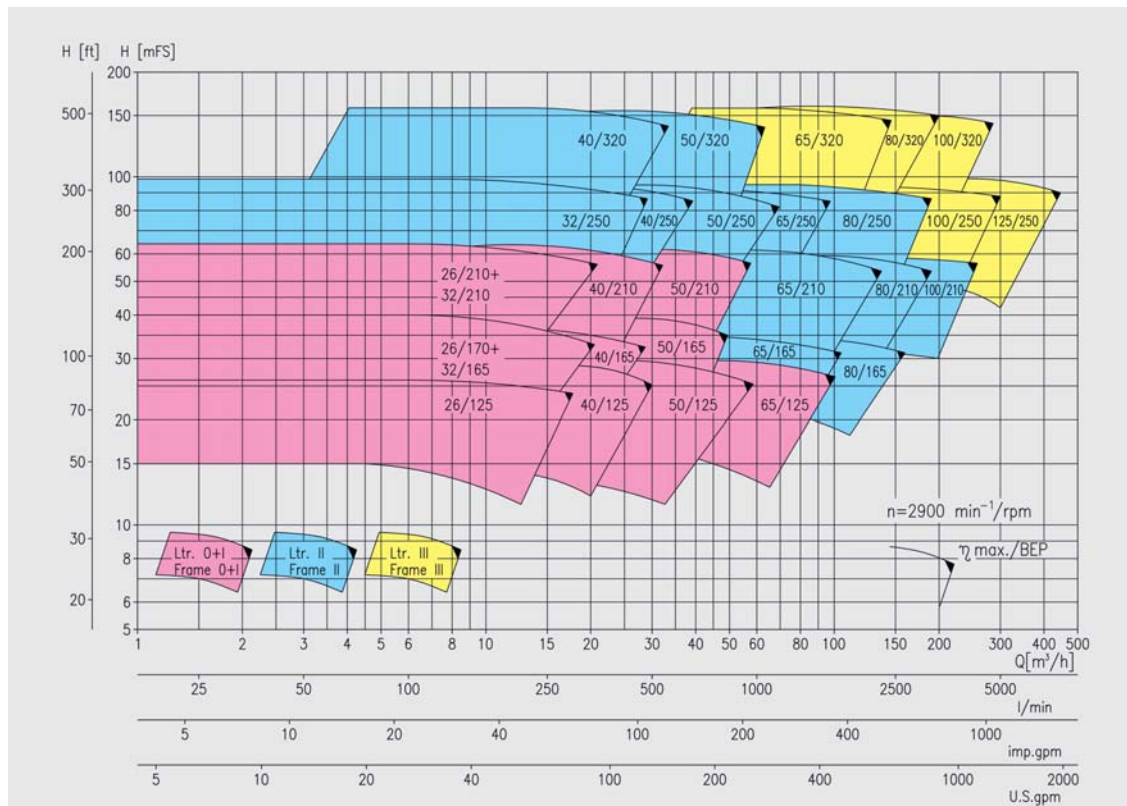
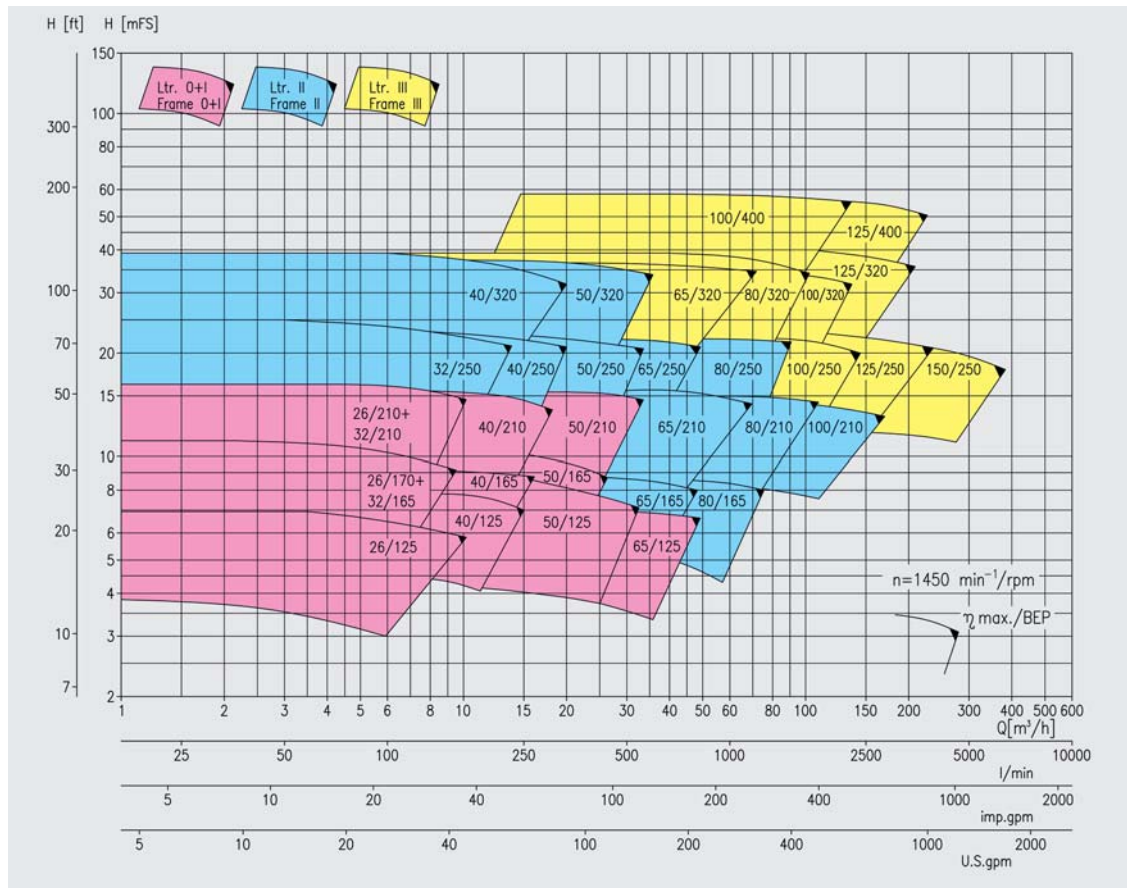

Performance curves for the individual pump sizes, also for 1750 / 3500 rpm, with NPSH-values and power consumption, are available on request.

